

Contact

Andrew Dinsdale
C/- KPMG
PO Box 996
Wellington

Phone: 04 802 1214
Fax: 04 802 1247

e-Mail: adinsdale@kpmg.co.nz

July 2005

Newsletter to Members

Greetings from Wellington

Don't be shocked, your President is still alive and well - we have started this newsletter many times but seemed to have struggled in getting it out. So here we go!

2005 AGM

The AGM was held prior to the opening of the 2005 Nationals in Tauranga. Minutes of the meeting have been completed and are being separately emailed to members.

2005 Nationals at Tauranga

Tauranga Nationals Report from Allan Fullerton

“The Appleton Estate Rum Elliott 5.9 Nationals 2005 has now come and gone. We now have a new National champion and congratulations must go out to the Burling family who sailed brilliantly the whole regatta. Tauranga turned on some great weather during the week of the event, although some would have preferred more wind. From an organiser's point of view, things couldn't have gone better. After getting over the initial problems of outboard motors etc everything went relatively smooth. The various events and functions that were organised were well patronised by the sailors. Blo-karting was definitely a hit with both sailors and Blokart alike. I think we can all imagine what a blast those things would be in a bit of breeze. In fact, it was decided between a few guys that every second nationals should be held using Blokarts! It certainly could be easier finding crew!! The day off on Wednesday gave most people a good opportunity to take a look around Tauranga. The PWG boys even got talked in to buying a new fizz boat! The TYPBC put on an excellent venue for the event. By the end of the week Sarah (the barmaid) knew what everybody was drinking and prize giving was a lot of fun, even without the President! Spagg's, at short notice, put on another side-splitting display of impromptu comedy at everyone else's expense! Allen McCormick from Appleton Estate put on an excellent “Rum Educational”. Some smart buggers thought they'd test the teacher's rum knowledge by filling one of their bottles with rum from the bar! Very clever!!

This nationals was, for me, successful in many different ways. The Tauranga guys got to show off our club facilities and the local region, and the weather made everything just that much better. It was also great to see different boats at the front of the fleet and racing so close that small mistakes were very costly. I would like to thank all the sponsors and everyone that helped with the organisation of this event, especially Brian Kent who organised the Bridge Marina Party and the race control boats, even though he wasn't able to sail himself. A big thanks to Appleton Estate Rum for their amazing support for this event and the class as a whole and to the Bay of Plenty Community Trust for their

generous donation. Thanks also to Steve's Marine Supplies for the 1st, 2nd and 3rd place goodies and the Bridge Marina Travel lift for a great party venue on Wednesday night. Last but certainly not least, thanks to everyone who travelled to Tauranga for the event. Such enthusiastic members are what make this class so strong. I hope you all enjoyed yourselves and will visit again."

Rank	Boat Name	Sail No	Helm	Club	R1	R2	R3	R4	R5	R6	R7	R8	R9	R10	R11	Nett
1	Ice Breaker	3976	Peter Burling	Tauranga	1	1	1	2	44	1	2	1	3	1	1	11
2	Slam Dunk	3700	C Horne	Auckland	6	4	2	5	1	3	1	4	2	6	2	24
3	Nevis	3099	G Smith	Tauranga	4	2	4	1	3	2	3	8	1	5	5	25
4	Lambada	3935	Simon Manning	Auckland	3	3	3	3	5	4	5	40	5	7	OCS	38
5	Brzo	3146	Paul Sloane	Tauranga	2	5	5	6	7	8	8	2	4	40	4	43
6	Cut Lunch	3231	Eric Knight	Onerahi	42	9	9	7	4	7	6	3	9	2	OCS	56
7	Spurt	3673	Allan Fullerton	Tauranga	7	7	6	4	2	44	7	11	6	44	6	56
8	Elliotness	3629	Rob Gill	RNZYS	5	8	45	12	6	5	9	13	44	4	3	65
9	PWB	3802	Andy Brown	Evans Bay	11	6	8	8	9	6	44	7	8	42	9	72
10	Blurr	3131	Mike Leyland	Evans Bay	8	11	12	11	11	13	4	OCS	10	13	OCS	93
11	Voodoo	3203	Andy McCallum	Evans Bay	13	13	11	46	13	10	13	44	11	3	7	94
12	Frivolous Fish	3744	H Swanson	Evans Bay	9	10	7	15	15	11	46	15	7	46	8	97
13	Luxury Liner	3690	Jonty Farmer	Tauranga	10	15	46	10	8	9	12	12	13	9	OCS	98
14	Sub 60	3760	Chris MacIndoe	Rotorua	48	14	10	9	17	48	11	9	12	8	10	100
15	Razor Back	3941	Allan Dunn	Evans Bay	14	12	14	13	12	12	47	6	15	47	11	109
16	Elliot Goblet	3580	R Watson	Evans Bay	16	48	13	14	16	47	10	5	17	11	12	114
17	Tight Fit	3590	Tony Poolman	Rotorua	15	47	17	17	10	15	15	16	16	48	13	134
18	Wtr Prf	4	Jason King	Keri Keri	17	16	48	48	18	16	18	17	18	15	14	149
19					DNC	DNC	DNC	DNC	DNC	DNC	DNC	DNC	DNC	DNC	DNC	180

2005 Appleton Estate Rum E5.9 Traveller Series

The proposed dates and locations of the five regattas for the 2005 Traveller Series are as follows:

Date	Event	Location	Notes
26/27 March 2005	Ends of the Island Regatta	Evans Bay, Wellington	In conjunction with the Easter Trailer Sailor Nationals
23/24 April 2005	Auckland Champs	RAYC, Auckland	In conjunction with the Magic 24 Nationals
16/17 July 2005	Taupo	Lake Taupo Yacht Club	In conjunction with the Nolex 25s
8/9 October 2005	Icebreaker	Rotorua Yacht Club	Note change of date in conjunction with the Noex 25s
19/20 November 2005	North Island Champs	Stump Bay Yacht Club, Turangi	Note change in date to avoid Round Taupo Cycle Race. Don't forget to book the Creel Lodge early

Ends of the Island Regatta, Evans Bay, Wellington - 26/27 March 2005

(Results and report on its way)

Auckland Champs - 23/24 April 2005

On Saturday races were completed in blustery conditions. Unfortunately on Sunday racing was cancelled due to high winds, so the regatta was decided on the 5 races completed on Saturday.

<i>Rank</i>	<i>Boat Name</i>
1	Slam Dunk
2	Zoot Allures
3	Hobo the Butcher
4	Cut Lunch
5	Animal Crackers
6	Spurt
7	Wtr Prf
8	Sub 60
9	Bombtrack

We will send you the updated series results once we have the results from Taupo this weekend.

Taupo - 16/17 July 2005

Dont forget this weekend is the third regatta in the 2005 Traveller Series being held at the Lake Taupo Yacht Club on Saturday 16 and Sunday 17 July. The E5.9 preferred accommodation is at Cutters Lakeview Motor Inn
60-62 Lake Tce, Taupo
Ph (0800) 288 8377
cutters-motorinn@clear.net.nz
<http://travelink.co.nz/nz/CuttersLakeviewMotorInn.html>

Unfortunately your President has to send his apologies due to KPMG client commitments (they pay the President's and his assistant's honorarium!!)

Elliott 5.9 Website

For those who are not yet aware you need to visit our new website at <http://www.e59.org.nz> which has been professionally designed by Ian MacIntosh. Many thanks to Ian for all his efforts.

Members can post information on the website by sending data to Ian at ian.macintosh@matrix.co.nz
Please follow a few simple rules as follows:

- *Pictures -In digital format (Ian is unable to scan anything). Please make sure photos have a meaningful name (i.e. Nats Tauranga)*
- *Please send results in an excel spreadsheet - named with the date, event and series. Final results only please, otherwise it will be confusing.*
- *Stories - text, etc - in plain tex format or MS Word. If there are pics to be added into the story, please put in a folder with the story.*

You can also use the website to advertise the sale of boats and other boating equipment.

The website will clearly make the dissemination of information much easier and will keep members up to speed with what is happening with their Class Association.

End of year financial report

We have completed the Financial Report for the year ended 31 May 2005 and this will be separately emailed to members. We have had a reasonably successful year helped by Appleton Estate (Lion Nathan Wines and Spirits) - sponsorship of \$1,000 together with generous Bay of Plenty Community Trust donation of \$2,000 (supporting the 2005 Nationals). Overall, the Association has finished the year with funds of \$8,086.21, an improvement on the opening position at 1 June 2004. This balance is after purchasing the Elliott 5.9 plans, moulds and intellectual property from Eagle Yachts New Zealand Limited and Ian Margan for \$2,000.

Elliott 5.9 Moulds

The Association now owns the plans, moulds and intellectual property and we now have our first new boat completed - courtesy of Keith Hogan, Sam Edwards and Greg Wagstaff. I know that Sam is keen to get the boat into the water but it looks like its debut will be Rotorua in October. The story on the build and the pictures of the yacht will be for the next newsletter.

2006 Nationals

The 2006 Elliott 5.9 Nationals will be held at the Kerikeri Cruising Club, Kerikeri from Monday, 6 February 2006 to Thursday, 9 February 2006. The AGM of the Association and measuring of boats will take place on Sunday, 5 February 2006.

Please book your accommodation early for the Nationals. Some accommodation to check out is as follows:

Colonial House Lodge Motels
178 Kerikeri Road
PO Box 37
kerikeri
Telephone No. 09 407 9106 or 0800 242 555
email colonial.lodge@xtra.co.nz
www.kerikeri.com/colonial

Palm Grove Cottages
410 Kerikeri Road
PO Box 706
Kerikeri
Telephone/Fax 09 407 8484
email: cottagemotel@xtra.co.nz
www.palmgrove.co.nz

Woodlands
126 Kerikeri Road
Kerikeri
Telephone 09 407 3947 or 0800 407 394
Fax 09 407 3948
web address: www.accommodationwoodlands.co.nz
email: woodlands.kerikeri@xtra.co.nz

Trailer skirts

Rob Gill wishes to thank members who have bought the skirts so far. Please don't forget to send in your measurement and order form (attached to this newsletter).

Finally, apologies for the delay in getting this newsletter out. Have a great time in Taupo - see you in Rotorua.

Happy Sailing

Regards

A handwritten signature in black ink that reads "Andrew J Dinsdale". The signature is written in a cursive style with a large initial 'A' and 'D'.

Andrew J Dinsdale (Dins)
President

Ordering your E5.9 Trailer Skirt

Measure 2.4m along the side beams starting from where the side beams meet the center beam. This point should be where the front of the boat is and where the winch is. Mark these 2 points.

Measure across the trailer from these 2 points and this will be measurement X.

Measure point Y. The width of the center beam.

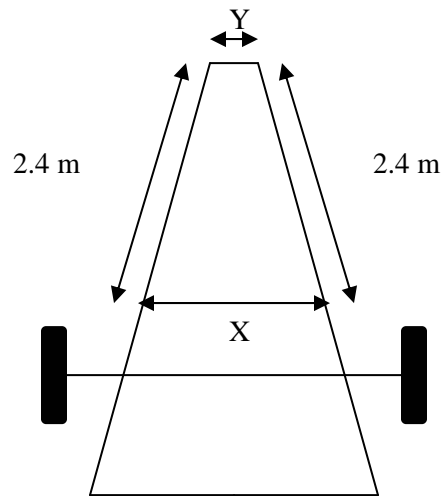

Name:

Boat name:

Address:

Phone number Wk:

Hm:

Mob:

Send the above details with a \$50 cheque (North Sails NZ Ltd) to:

Derek Scott

One Design Manager

North Sails NZ Ltd

PO Box 37419, Parnell, Auckland.

Pakenham Street, Viaduct Basin, Auckland.

Ph 0064 9 3595999

Mob 0064 21 1297821

Fax 0064 9 359 5995

derek@nz.northsails.com